

Transmissive Optical Sensor

Description

This device has a compact construction where the emitting light sources and the detectors are located face to face on the same optical axes. The operating wavelength is

950 nm. The detector consists of a photologic-IC with Schmitt-trigger and open collector output.

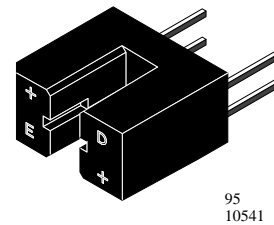
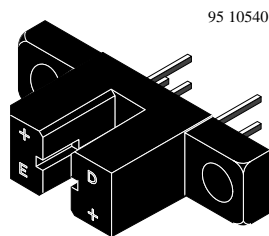

Applications

- Detection of opaque material, documents etc.
- Paper position sensor in copy machines.
- Position sensor for shaft encoder.

Features

- Output: "LOW" when infrared beam is not interrupted
- Inverter-open collector
- TTL compatible
- Built in voltage regulator
- Case plastic polycarbonate-protected against ambient light
- No adjustment necessary
- Applicable connector AMP 171 825-3
- Aperture size 1 mm
- Two package variations

Pin Connection

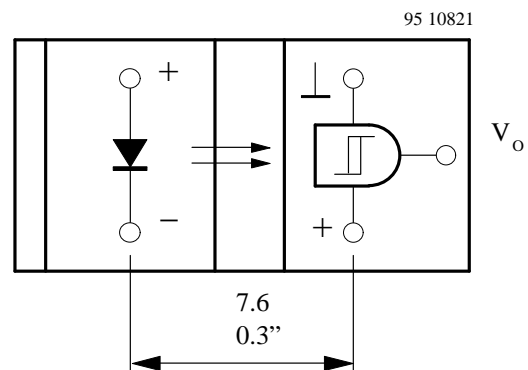

Absolute Maximum Ratings

Input (Emitter)

| Parameters | Test Conditions | Symbol | Value | Unit |
|-----------------------|---------------------------|-----------|-------|------------|
| Reserve voltage | | V_R | 6 | V |
| Forward current | | I_F | 60 | mA |
| Forward surge current | $t_p \leq 10 \mu s$ | I_{FSM} | 3 | A |
| Power dissipation | $T_{amb} \leq 25^\circ C$ | P_V | 100 | mW |
| Junction temperature | | T_j | 100 | $^\circ C$ |

Output (Detector)

| Parameters | Test Conditions | Symbol | Value | Unit |
|----------------------|---------------------------|----------|-------|------------|
| Supply voltages | | V_{S1} | 16 | V |
| | | V_{S2} | 20 | V |
| Output current | | I_o | 20 | mA |
| Power dissipation | $T_{amb} \leq 25^\circ C$ | P_V | 50 | mW |
| Junction temperature | | T_j | 100 | $^\circ C$ |

Coupler

| Parameters | Test Conditions | Symbol | Value | Unit |
|---------------------------|------------------------------|-----------|-------------|------------|
| Total power dissipation | $T_{amb} \leq 25^\circ C$ | P_{tot} | 150 | mW |
| Ambient temperature range | | T_{amb} | -25 to +85 | $^\circ C$ |
| Storage temperature range | | T_{stg} | -40 to +100 | $^\circ C$ |
| Soldering temperature | 2 mm from case, $t \leq 5 s$ | T_{sd} | 260 | $^\circ C$ |

Electrical Characteristics $T_{amb} = 25^\circ C$

Input (Emitter)

| Parameters | Test Conditions | Type | Symbol | Min. | Typ. | Max. | Unit |
|----------------------|----------------------|------|------------|------|------|------|------|
| Forward voltage | $I_F = 50 mA$ | | V_F | | 1.25 | 1.6 | V |
| Breakdown voltage | $I_R = 100 \mu A$ | | $B_{(BR)}$ | 6 | | | V |
| Junction capacitance | $V_R = 0, f = 1 MHz$ | | C_j | | 50 | | pF |

Output (Detector)

| Parameters | Test Conditions | Type | Symbol | Min. | Typ. | Max. | Unit |
|----------------------|-----------------|------|----------|------|------|------|------|
| Supply voltage range | | | V_{S1} | 4.5 | | 16 | V |

Coupler

| Parameters | Test Conditions | Type | Symbol | Min. | Typ. | Max. | Unit |
|-------------------------|---|------|--------------------|------|------|------|---------|
| Supply current | $V_{S1} = 16 V$ | | I_{S1} | | 3 | 5 | mA |
| Output current | $V_{S1} = V_{S2} = 16 V, I_F = 0$ | | I_{OH} | | | 1 | μA |
| Input threshold current | $V_{S1} = 5 V$ | | I_{FT} | | 5 | 10 | mA |
| Hysteresis | $V_{S1} = 5 V$ | | I_{Foff}/I_{Fon} | | 80 | | % |
| Output voltage | $I_{OL} = 16 mA, I_F \geq I_{TF}, V_{S1} = 5 V$ | | V_{OL} | | 0.15 | 0.4 | V |
| Switching frequency | $I_F 3x I_{FT}, V_{S1} = V_{S2} = 5 V, R_L = 1 k\Omega$ | | f_{sw} | | 200 | | kHz |

Switching Characteristics

$V_{S1} = V_{S2} = 5\text{ V}$, $I_F = 3 \times I_{FT}$, $R_L = 1\text{ k}\Omega$, see test circuit

| Parameters | Test Conditions | Symbol | Value | Unit |
|---------------|-----------------|-----------|-------|---------------|
| Rise time | | t_r | 50 | ns |
| Turn-on time | | t_{on} | 1 | μs |
| Fall time | | t_f | 20 | ns |
| Turn-off time | | t_{off} | 3 | μs |

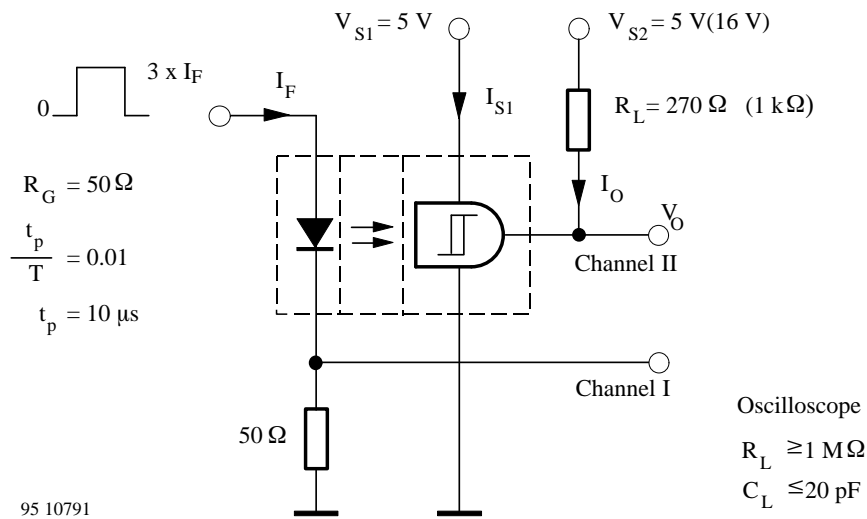

Figure 1. Test circuit for: t_r , t_{on} , t_f , t_{off}

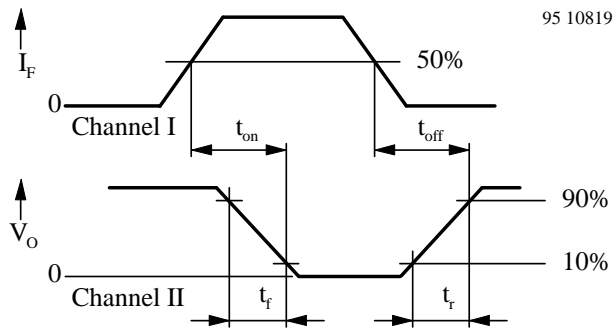

Figure 2. Pulse diagram

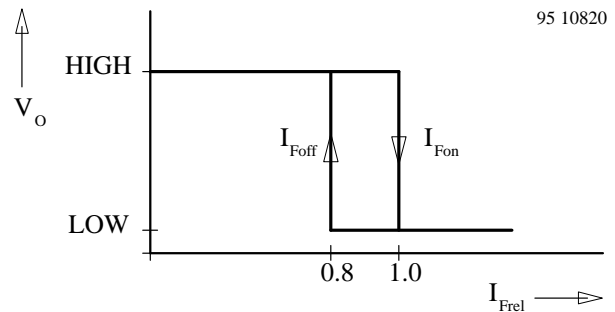

Figure 3. Hysteresis

Ozone Depleting Substances Policy Statement

It is the policy of **TEMIC TELEFUNKEN microelectronic GmbH** to

1. Meet all present and future national and international statutory requirements.
2. Regularly and continuously improve the performance of our products, processes, distribution and operating systems with respect to their impact on the health and safety of our employees and the public, as well as their impact on the environment.

It is particular concern to control or eliminate releases of those substances into the atmosphere which are known as ozone depleting substances (ODSs).

The Montreal Protocol (1987) and its London Amendments (1990) intend to severely restrict the use of ODSs and forbid their use within the next ten years. Various national and international initiatives are pressing for an earlier ban on these substances.

TEMIC TELEFUNKEN microelectronic GmbH semiconductor division has been able to use its policy of continuous improvements to eliminate the use of ODSs listed in the following documents.

1. Annex A, B and list of transitional substances of the Montreal Protocol and the London Amendments respectively
2. Class I and II ozone depleting substances in the Clean Air Act Amendments of 1990 by the Environmental Protection Agency (EPA) in the USA
3. Council Decision 88/540/EEC and 91/690/EEC Annex A, B and C (transitional substances) respectively.

TEMIC can certify that our semiconductors are not manufactured with ozone depleting substances and do not contain such substances.

We reserve the right to make changes to improve technical design and may do so without further notice.

Parameters can vary in different applications. All operating parameters must be validated for each customer application by the customer. Should the buyer use TEMIC products for any unintended or unauthorized application, the buyer shall indemnify TEMIC against all claims, costs, damages, and expenses, arising out of, directly or indirectly, any claim of personal damage, injury or death associated with such unintended or unauthorized use.

TEMIC TELEFUNKEN microelectronic GmbH, P.O.B. 3535, D-74025 Heilbronn, Germany
Telephone: 49 (0)7131 67 2831, Fax number: 49 (0)7131 67 2423